

**OPTIONAL ELECTRIC ELEMENT  
INSTALLATION**

**MAX CADDY FURNACE**



## OPTIONAL ELECTRIC ELEMENT INSTALLATION

Your Max Caddy furnace can be installed with an optional electric element (20 or 25 kW). This option can be installed on either side of your furnace.

*Please note that the installation procedure is carried out in an identical way no matter which electric element is used.*

### RIGHT SIDE INSTALLATION

Step 1 : Remove the electric element lid and the right panel located at the right of the furnace by unscrewing the screws maintaining them in place. Keep these screws.

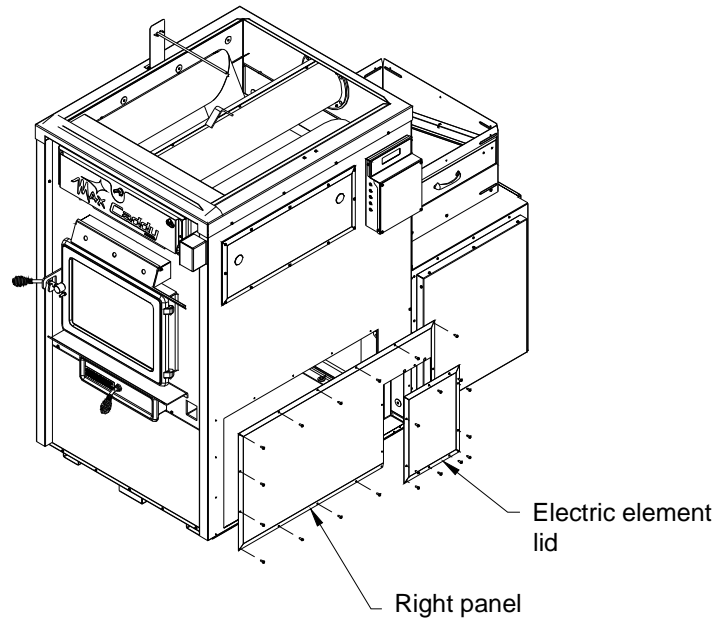

Step 2 : Remove the right panel of the electric element by unscrewing the 5 screws. Keep the screws. Unscrew the screw located at the top surround of the electric element housing (see figure 1). Keep this screw. You will need it for Step 5. Remove the thermostat located inside of the electric element housing. Before installing the housing inside the furnace, it is advised to do the wiring connections. In order to do so, you can remove one of the side panels of the electric element housing. You may now install the electric element inside the furnace.

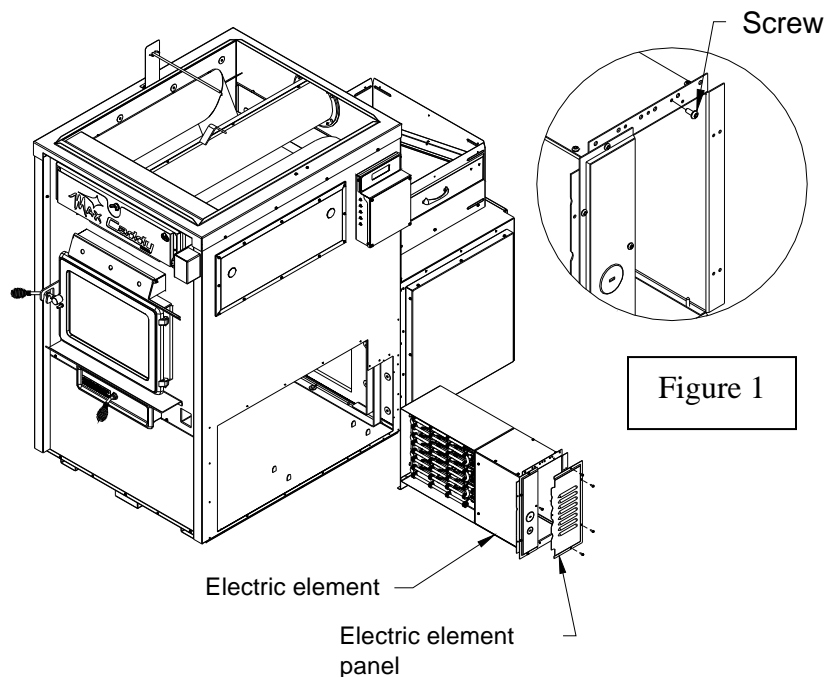

Figure 1

Step 3 : To secure the electric element housing in place, use the four screws kept from Step 1. Make sure that you screw them in the right holes (see figure 2, the holes are identified with arrows). The upper part comprises several holes and these holes are specific to the desired installation (left or right).

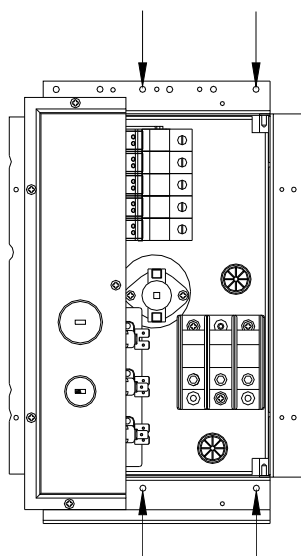
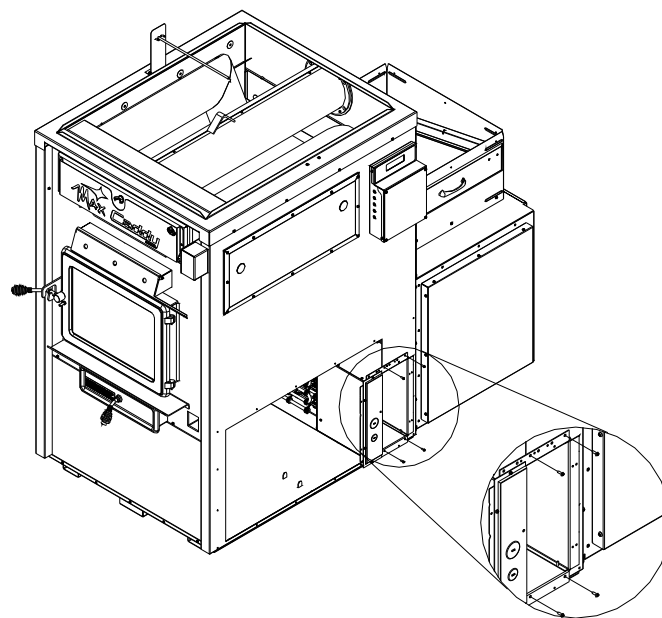
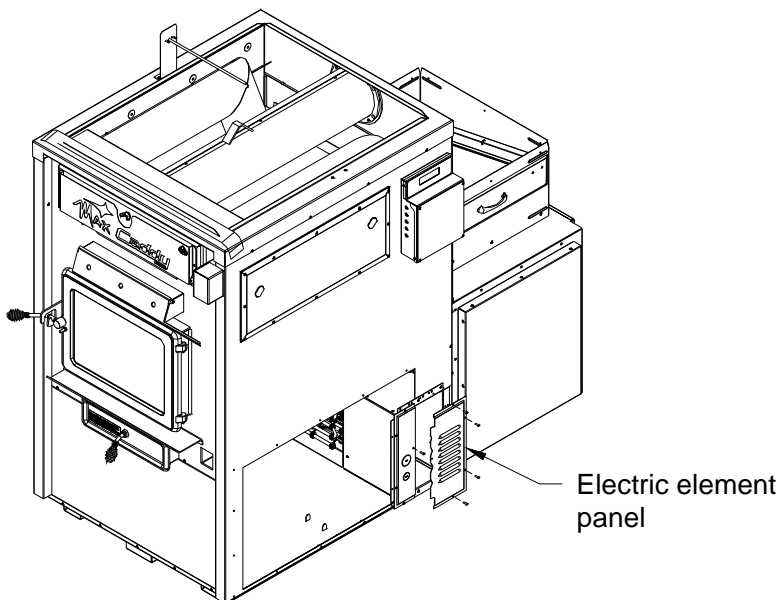

Figure 2



Step 4 : Screw the right panel of electric element back in place using the 5 screws kept from Step 2.



Step 5 : Screw the right panel of the furnace back in place. Use the screw kept from Step 2. It passes through the right panel of the furnace and the electric element to secure the assembly onto the wall of the furnace.

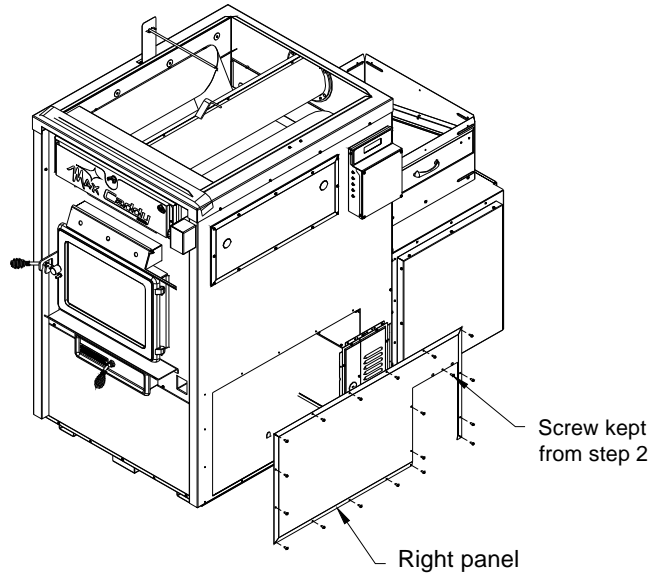

## LEFT SIDE INSTALLATION

Step 1 : Remove the electric element lid and the left panel located at the left of the furnace by unscrewing the screws maintaining them in place. Keep these screws.

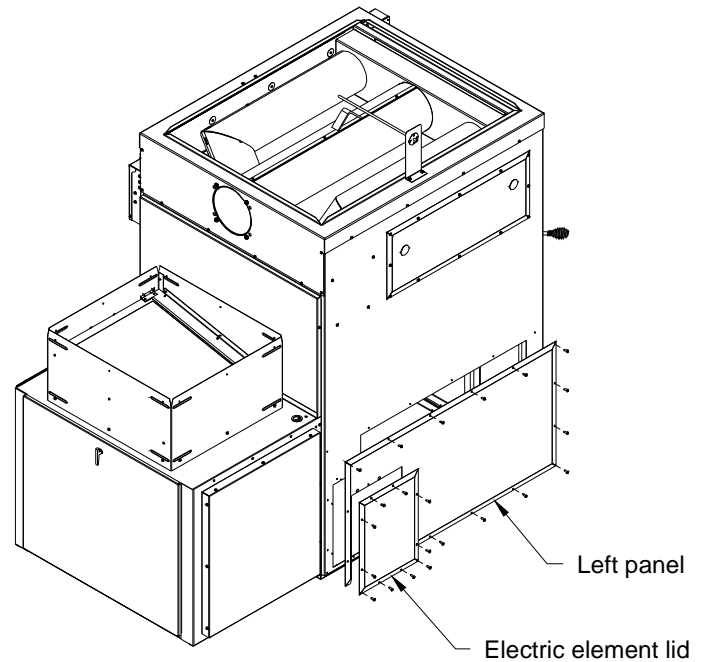

Step 2 : Remove the left panel of the electric element by unscrewing the 5 screws. Keep the screws. Unscrew the screw located at the top surround of the electric element housing (see figure 3). Keep this screw. You will need it for Step 5. Remove the thermostat located inside of the electric element housing. Before installing the housing inside the furnace, it is advised to do the wiring connections (see appendix A). In order to do so, you can remove one of the side panels of the electric element housing. You may now install the electric element inside

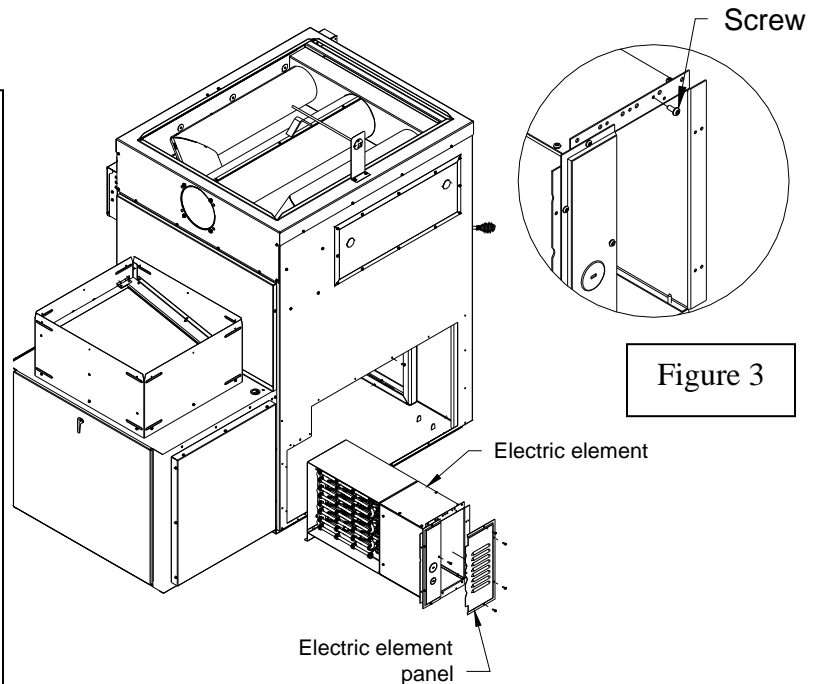

Step 3: To secure the electric element housing in place, use the four screws kept from Step 1. Make sure that you screw them in the right holes (see figure 4, the holes are identified with arrows). The upper part comprises several holes and these holes are specific to the desired installation (left or right).

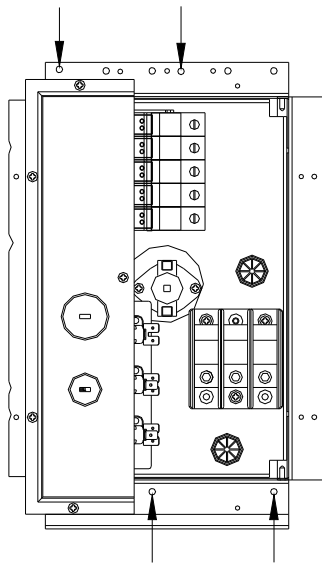
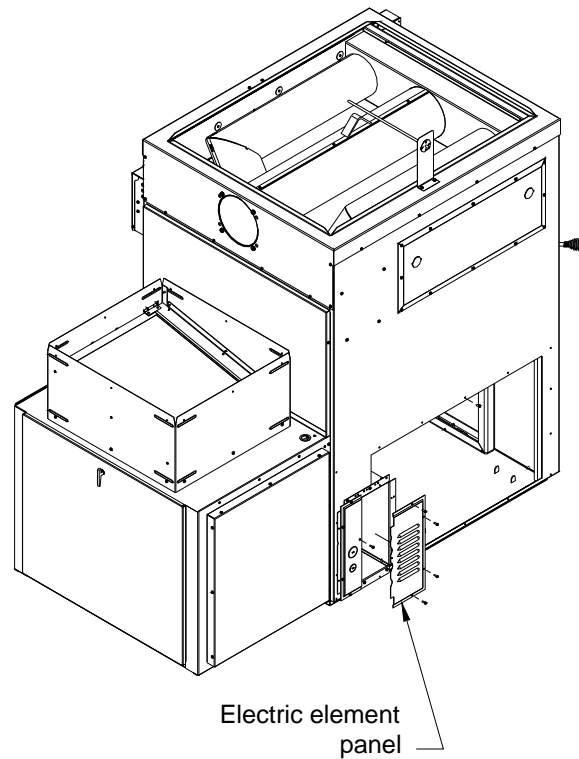
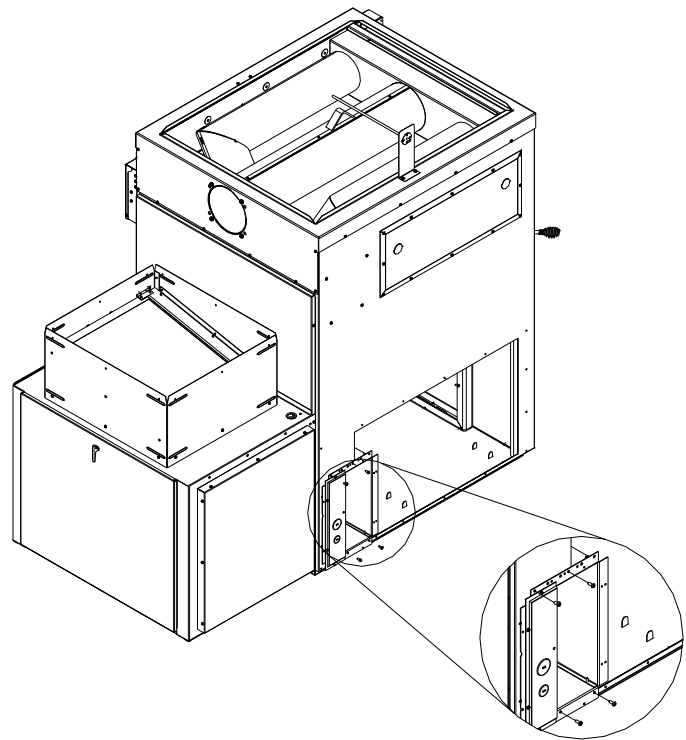

Figure 4

Step 4: Screw the left panel of electric element back in place using the 5 screws kept from Step 2.



Electric element panel

Step 5 : Screw the left panel of the furnace back in place. Use the screw kept from Step 2. It passes through the left panel of the furnace and the electric element to secure the assembly onto the wall of the furnace.

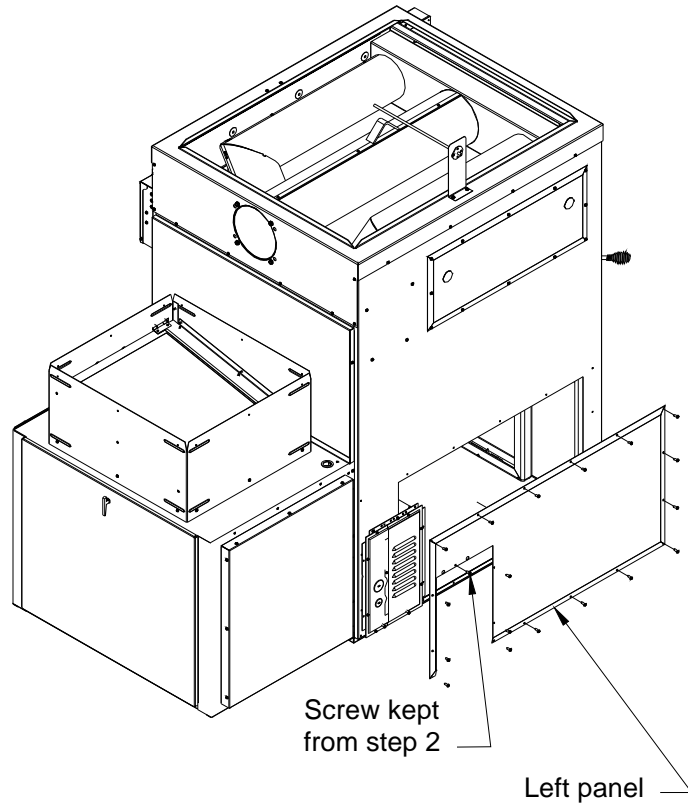

## Appendix A

Step 1 : Assemble 2 wires (18 ga) with a female connector at one end and skinned at the other end.

Step 2 : Connect the 2 wires to the « ELEC HEAT » port of the PC board and to the thermodisc and electrical sequencer.

Step 3 : Hook up the main electrical supply to ports L1, N, L2, G located inside the electrical unit.

